

M-PRV-S
PRESSURE REDUCING VALVE
Instruction Manual

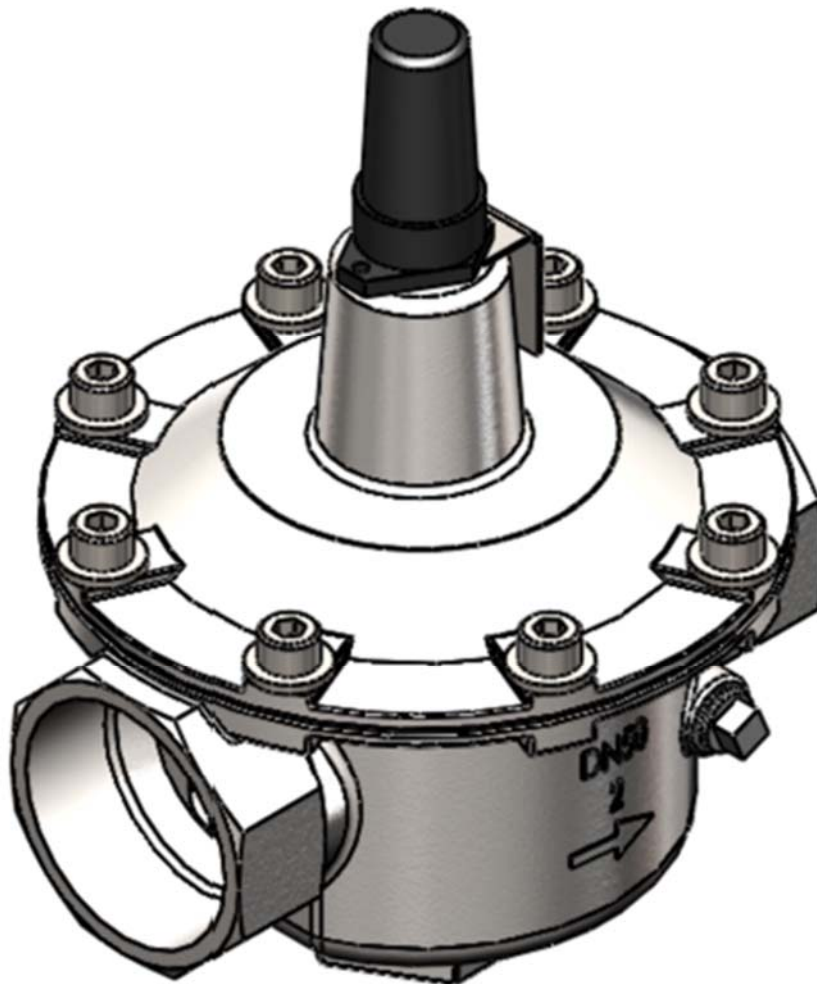

TOZEN

Thank you very much for purchased Tozen products.

Please read the Instruction Manual before use to ensure using this product in correctly and safely way.

The definition of the symbol use in the text as below shown: -

-  **Caution** : If did not implement protection measure, may cause minor injury or parts damaged.

Contents

1. Application
2. Specification
3. Installation
 - 3.1 Installation Example
 - 3.2 Precaution
4. Operation Manual
 - 4.1 Precaution
 - 4.2 Procedure
5. Maintenance Manual
 - 5.1 Inspection Item
 - 5.2 Exploded View
6. Cause & Counter Measure Of Malfunction
7. Sizes Selection Diagram & Pressure Reducing Valve Flow Chart

1. Application

Building equipment, air-conditioning equipment, factory equipment, irrigation facility, the water supply piping to reduce pressure and maintain a certain pressure range on outlet or downstream side.

2. Specification

Model	M-PRV-S	
Sizes (mm)	20~50	
Application Fluid	Water, Warm Water	
Fluid Temperature	5~60°C	
Applicable Inlet Pressure	Under 1.6MPa	
Max. Pressure Reduction Ratio	10 : 1	
Connection	Rc(JIS B 0203, ISO 7/1, BS 21)	
Material	Body, Bonnet	SCS13A
	Diaphragm, Seat, O-Ring	NBR

Caution

- To use this product, please make sure can meet the application condition.

3. Installation

3.1 Installation Example

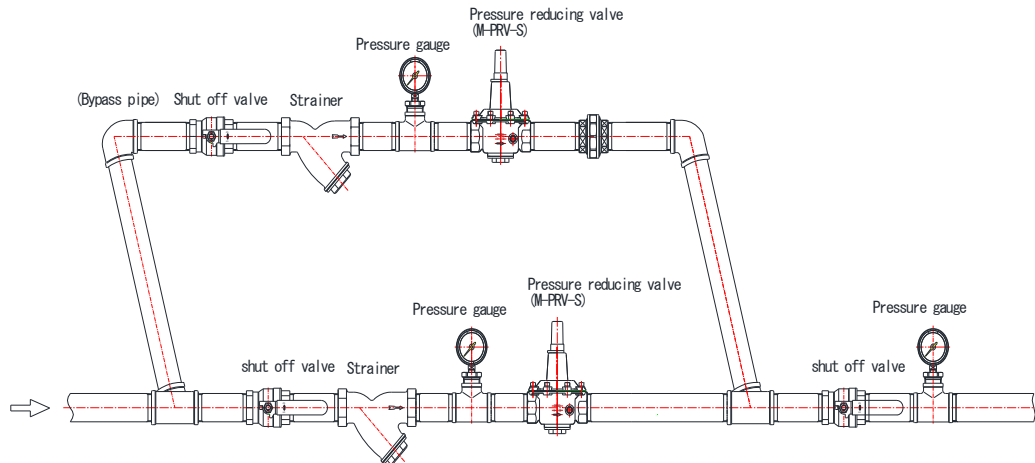

3.2 Precautions

Caution

- Make sure the valve's flow arrow direction follow the pipe flow direction when install the valve.
 - ※ There are no function if installed wrong direction.
- During installation, other than main body threaded end part, don't use spanner or others to tightening others part.
 - ※ If the valve deformed, the valve will not do the job.
- Make sure the liquid sealant do not flow in to the valve body during installation.
 - ※ The valve will not work properly
- Propose to install strainer (40 mesh or above) on inlet side.
 - ※ The valve can't have the original performance and may damage if foreign particle in the valve.
- Must install stop valve on both inlet & outlet side.
 - ※ Unable to do maintenance if do not have stop valve
- It is recommended to install by-pass line.
 - ※ When doing maintenance, the water flow may stop if do not have by-pass line.

4. Operation Manual

4.1 Precautions

Caution

- Remove the foreign particles in the pipe line before install the valve.
 - ※The valve can't have the original performance and may damage if foreign particles in the valve.
- When water flow, to avoid happened water hammering, please slowly open the stop valve.
 - ※If rapidly open the stop valve, hunting and water hammering may occurred, also may damage the system.

4.2 Procedure

- ①Please close the shut off valve at inlet side, outlet side and by-pass line.
- ②Slowly open the shut off valve on inlet side, let the water flow. Then slowly open the outlet side shut off valve to let the air relief, let the water flow awhile. After the air relief, outlet side decompression start operate.
- ③To setting outlet pressure, removed the cap which on top of the pilot valve, with confirmation from pressure gauge, clockwise turn the adjustment bolt, the outlet pressure will increase, turn anti clockwise will reduce the pressure.

5. Maintenance Procedures

Caution

- To maintain this product's function & performance, please perform daily checking and regular inspection.
- To dismantle the valve, please perform by the skilled specialist (facility contractor).
 - ※If done by normal people, the valve may lost the adjusting function.

5.1 Inspection Item

- ①Please confirm if there are any water leaking on the system
- ②Use pressure gauge to confirm the inlet and outlet pressure.
- ③Please clean the strainer mesh if there are foreign particles stuck on it.

5.2 Exploded View

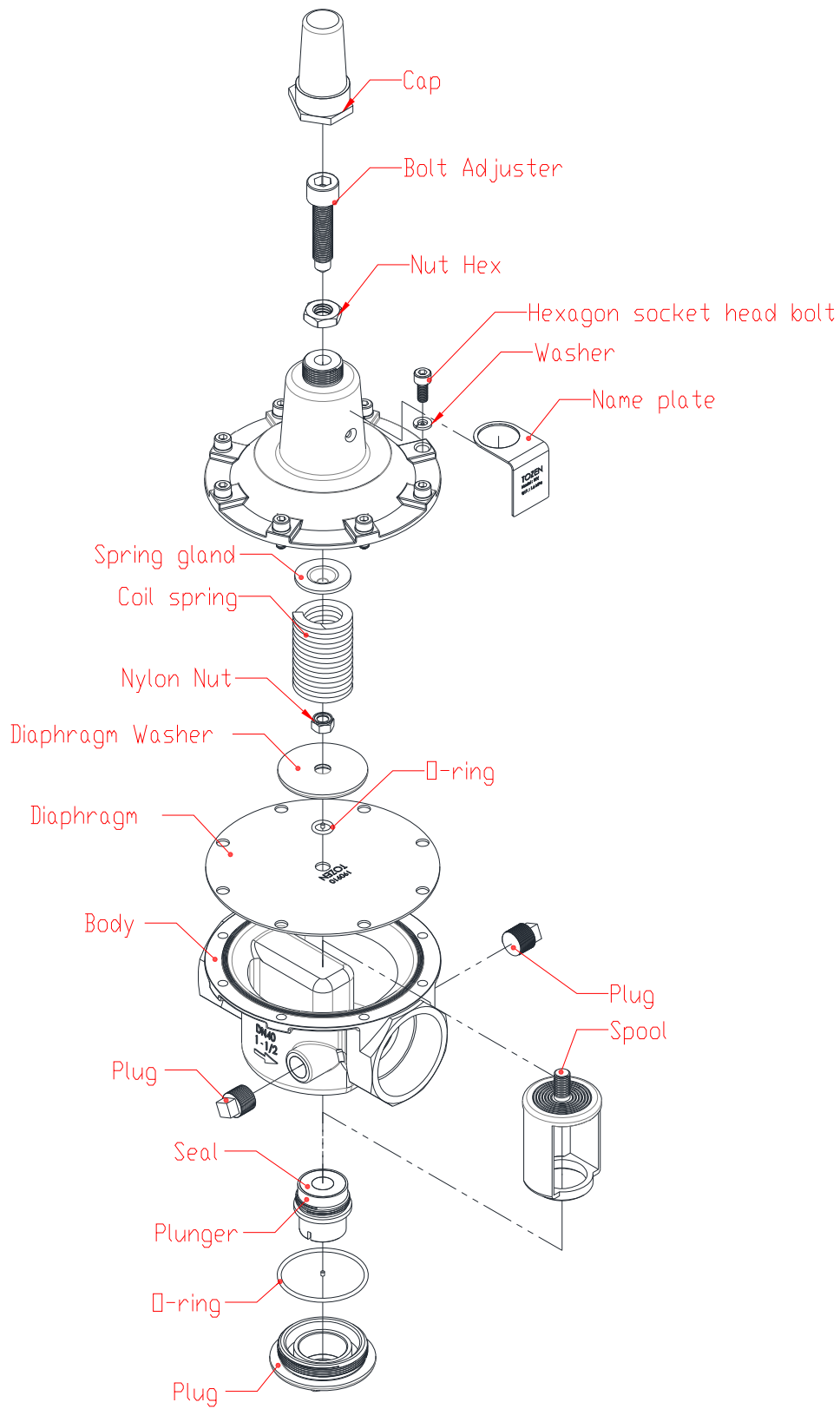

6. Cause & Counter Measure Of Malfunction

Condition	Possible Cause	Countermeasure
Outlet side pressure does not rise.	Not proper setting the pressure	Re-setting
	Strainer Clogging	Dismantle the strainer, clean the mesh.
	Pressure gauge malfunction	Exchange the pressure gauge
Outlet side pressure increase	Foreign particle stuck on seal, valve seat.	Dismantle and clear the particle. If the seal or valve seat damaged, repair or exchange
	By-pass line stop valve leaking	Repair or replace
Abnormal noise occur	Pressure reduction ratio too big	2 stage reduce pressure
	Open/Close the stop valve rapidly near pressure reducing valve	Keep the distance as far as possible

7. Sizes Selection Diagram & Pressure Reducing Valve Flow Chart

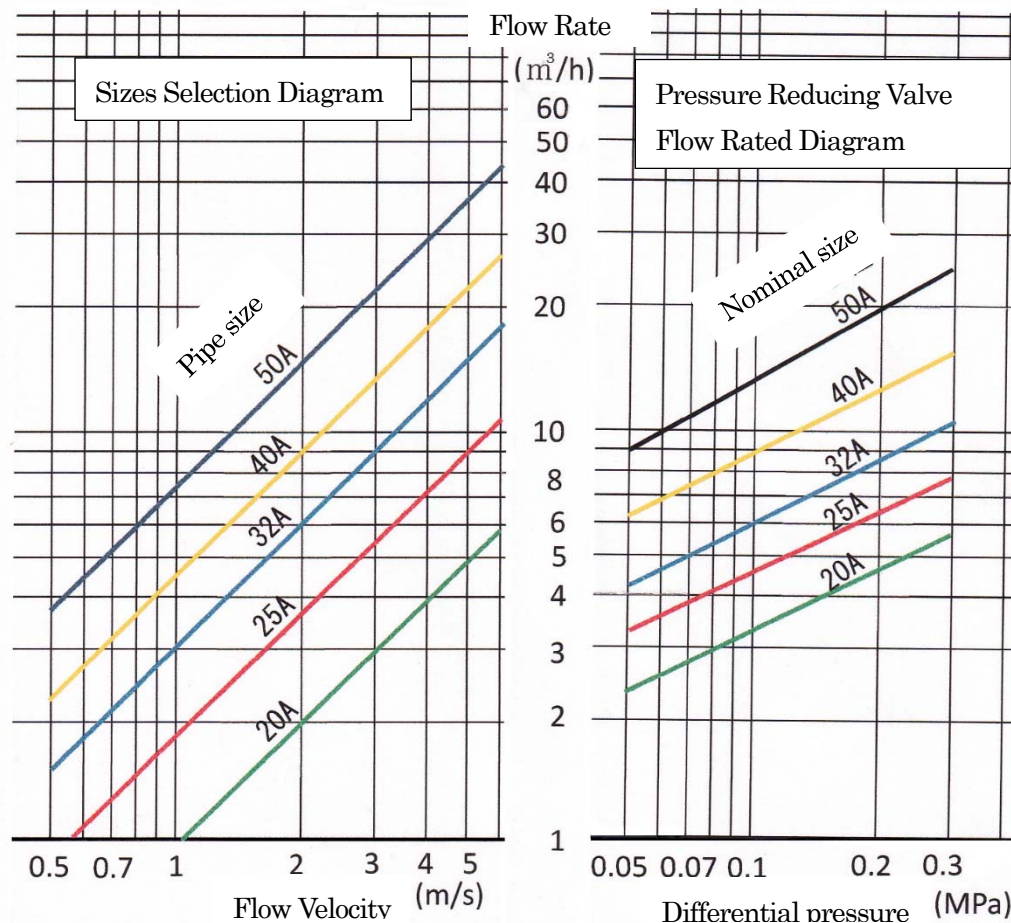

(Note) To consider the noise occur and durability, the ideal piping flow velocity is under 2m/s