

20220222

PRV-CPR

Pressure Reducing valve

Instruction Manual

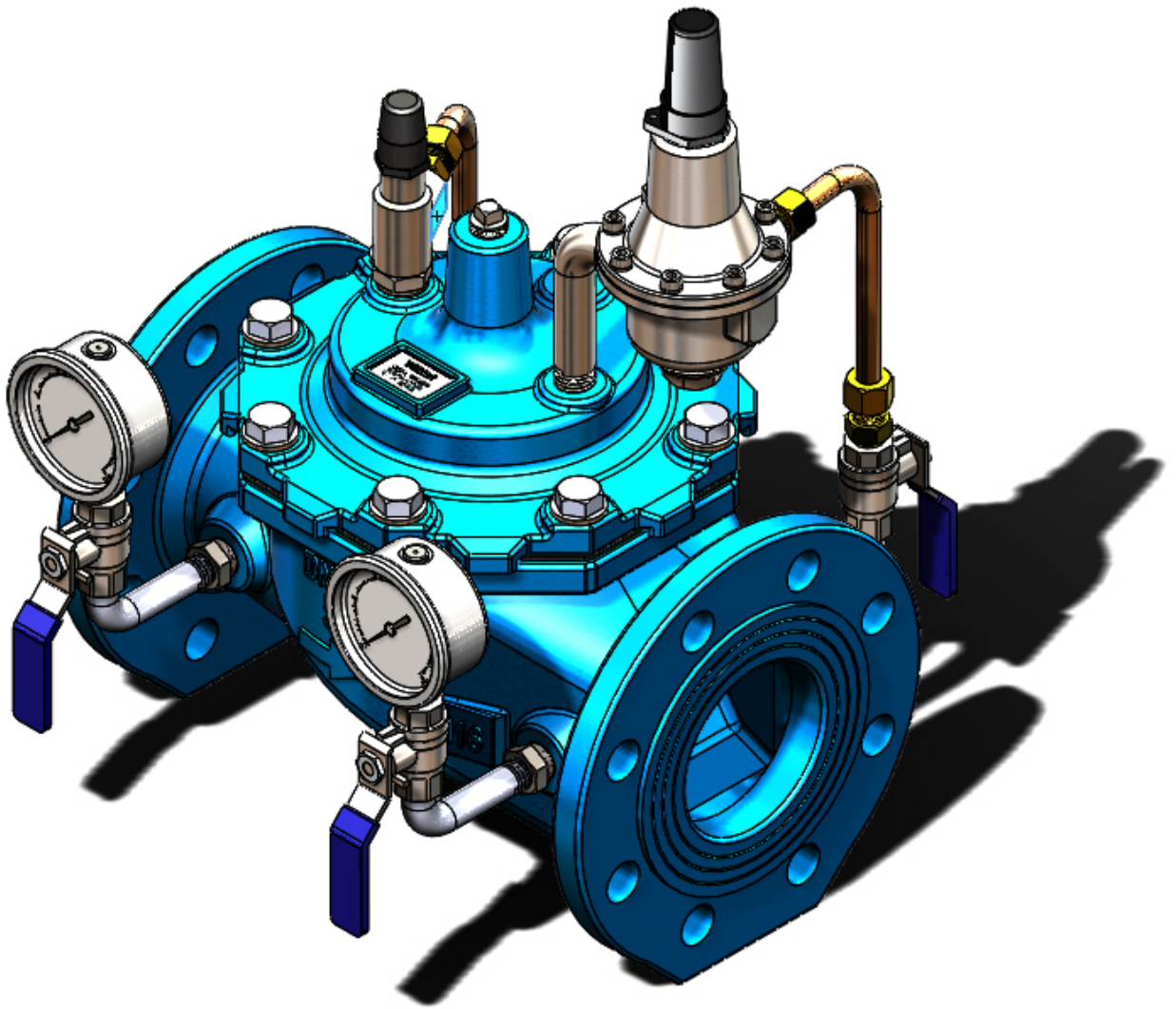



TOZEN

Thank you very much for purchased Tozen products.

Please read the Instruction Manual before use to ensure using this product in correctly and safely way.

The defination of the symbol use in the text as below shown:-

·  **Warning** : If did not implement protection measure, may result in death or seriously injury.

·  **Caution** : If did not implement protection measure, may caused minor injury or parts damaged.

Contents

1. Application
2. Specification
3. Operation
4. Installation
 - 4.1 Installation example
 - 4.2 Precaution
 - 4.3 Installation Space
5. Operation Manual
 - 5.1 Precaution
 - 5.2 Procedure
6. Maintenance Manual
7. Cause & Counter Measure Of Mulfunction
8. Nominal Size Seletion Chart(For water)

1. Application

Building equipment, air-conditioning equipment, factory equipment, irrigation facility, the water supply piping to reduce pressure on outlet or downstream side and maintain a certain range.

2. Specification

Model	PRV-CPR	
Sizes (mm)	65~150	
Application Fluid	Water, Warm Water	
Fluid Temperature	5~60°C	
Applicable Inlet Pressure	Under 1.6MPa	
Max. Pressure Reduction Ratio	10 : 1	
Connection	BS4504,EN1092-2	
Material	Body	FCD450
	Main Part	Seat : SCS13A, Diaphragm, Shield Ring : NBR

Caution

- To use this product, please make sure can meet the application condition.
- Please do daily checking and periodic inspection to maintain this product's function and performance.

3. Operation

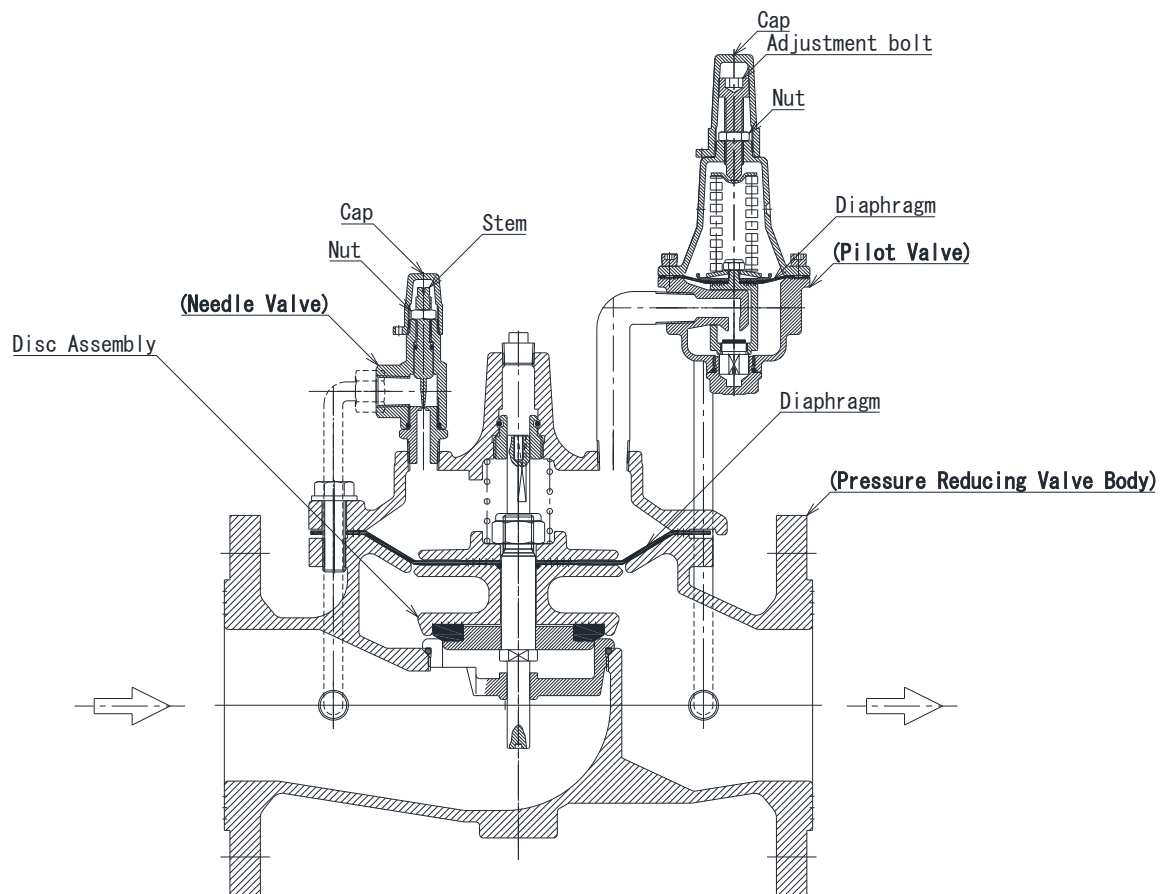

1. The PRV-CPR body 's disc assembly will rises and the PRV-CPR valve opened from inlet pressure.
Or haven't adjusting the pilot valve, the needle valve under opened condition and no heavy load on adjusting bolt, the fluid will let through pilot tube to pilot valve from upper part of the diaphragm in the PRV-CPR body.
2. The lower part of the diaphragm in the pilot valve pressure increaase, the disc assembly of the pilot valve will rise, and the pilot valve will closed.
3. The pilot valve closed, the upper part of the diaphragm in the PRV-CPR body pressure will increase, the PRV-CPR disc assembly will drop down, and the PRV-CPR closed.
4. To setting outlet pressure of the PRV-CPR, removed the cap which on top of the pilot valve, clockwise turn the adjustment bolt, the outlet side pressure will increase, turn anti clockwise will reduce the pressure.

4. Installation

4.1 Installation Example

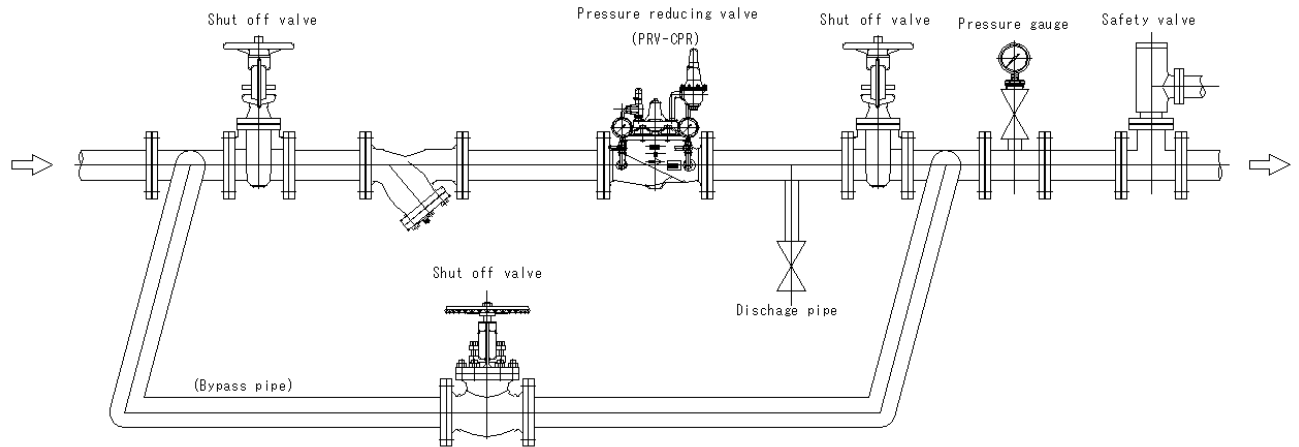

4.2 Precaution

Warning

- Please pay necessary attention make sure have proper support when install this product to the pipe system, as this product is heavy.
 - ※In case of this product drop down, there is a risk to get hurt.
- After installation, before water flow, make sure all the pipe work been proper installed.
 - ※If the water spouting off the pipe line, it may dirty the surrounding and there is a risk to get hurt.

Caution

- Remove the foreign matters in the pipe line before install the valve.
 - ※The valve can't have the original performance and may damage if foreign particle in the valve.
- Propose to install strainer (40 mesh or above) on inlet side.
 - ※The valve can't have the original performance and may damage if foreign particle in the valve.
- Must install stop valve on both inlet & outlet side.
 - ※Unable to do maintenance if do not have stop valve.

- It is recommended to install by-pass line.
※When doing maintenance, the water flow may stop if do not have by-pass line.
- Make sure the valve's flow arrow direction follow the pipe flow direction when install the valve.
※There are no function if installed wrong direction.
- Please proper support the pipe line to avoid the valve facing the pipe weight, unreasonable force, bending, vibration.
※If do not support the pipe line properly, the valve may damage or the reason of operation failure.
- To avoid pipe freezing, drain the pipe water and thermal insulation the pipe.
※By freezing, may damaged the valve.
- Please secure the installation space. (refer to 4.3 Installation Space)
※When doing maintenance and inspection, unable to dismantle and assembly the valve if do not have enough space.
- The valve can be install to horizontal and verticle pipe line. For verticle pipe line, when doing maintenance and inspection, may have difficulty to dismantle and assembly the valve. It is recommended to install on horizontal pipe.
※For verticle pipe line, especially dismantle the heavy and big sizes valve, may accidentally damage the parts.

4.3 Installation Space

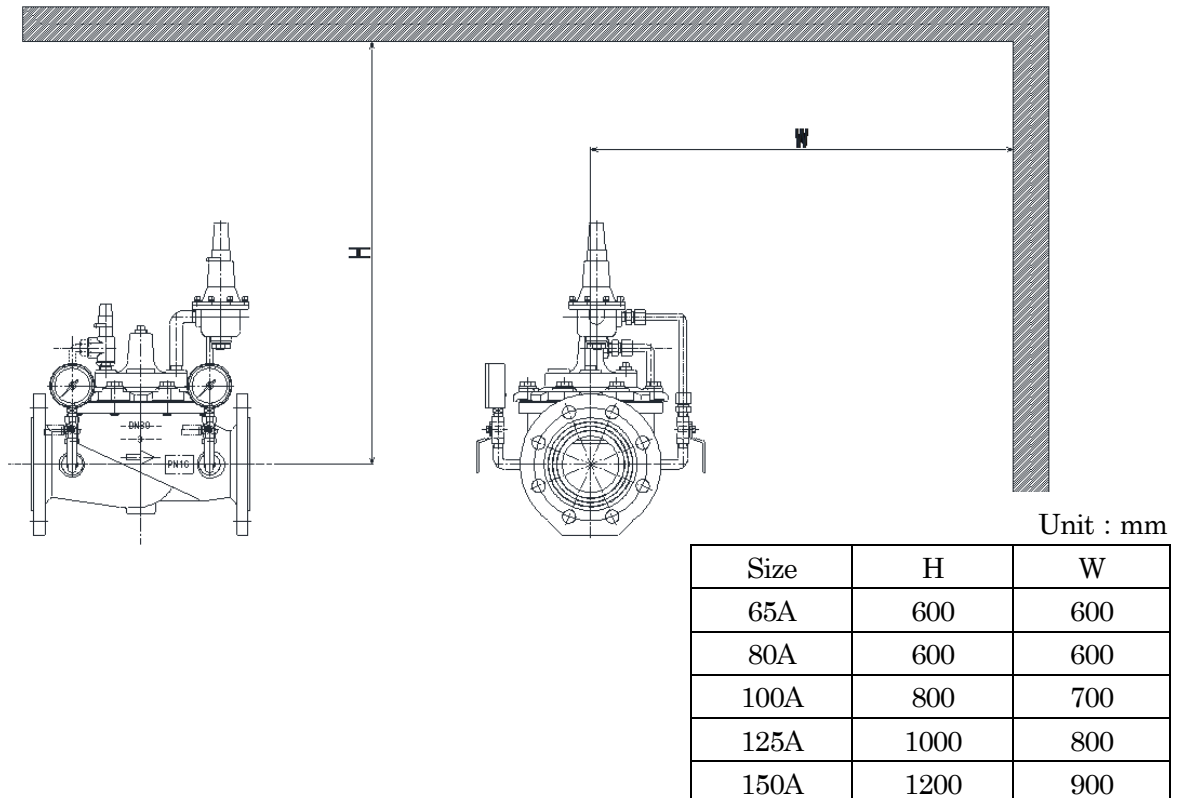

5. Operation Manual

5.1 Precautions

Warning

- After installation, before water flow, make sure all the pipe work been proper installed.
 - ※If the water spouting off the pipe line, it may dirty the surrounding and there is a risk to get hurt.

Caution

- Remove the foreign particles in the pipe line before install the valve.
 - ※The valve can't have the original performance and may damage if foreign particles in the valve.
- When water flow, to avoid happened water hammering, please slowly open the stop valve.
 - ※If rapidly open the stop valve, hunting and water hammering may occurred, also may damage the valve.
- If the pipe line long period not running, closed the stop valve, drain dry the valve and pipe line.
 - ※The water dirt in the pipe line may caused operation failure.
- If open the shut off valve of the by-pass line, make sure the outlet pressure not over the outlet setting pressure by confirmation with pressure gauge and slowly adjust the valve.

5.2 Procedure

- ①Please close the shut off valve at inlet side, outlet side and by-pass line.
- ②Open the valve from supply source, then slowly open the by-pass line's shut off valve, let the water flow cleaning the pipe.
- ③Close the by-pass line's shut off valve.
- ④At inlet side, turn the shut off valve to around half open, then slowly turn the shut off valve to around 1/4 open at outlet side, let the water flow awhile. This is to let the air out of the pipe, the product internal air can get out, at outlet side the valve should start function to reduce the pressure.
When occurred hunting or no pressure reduce function, turn the bonnet plug open, let the air out of the valve body.

Caution

- Please do not open the shut off valve at outlet side bigger than inlet side.
 - ※Hunting and water hammering may occurred.

- ⑤ If no happened abnormal, fully open the inlet side shut off valve, then fully open outlet side shut off valve.
- ⑥ To setting outlet side pressure, open the upper cap of the pilot valve, checking the the pressure gauge at outlet side, to let the setting pressure higher, turn the adjusting bolt clockwise, to lower the setting pressure, turn to anti clockwise.

6. Maintenance Procedures

Warning

- If want to dismantle the valve, close the Inlet side shut off valve, drain the water out from the valve body, outlet side pressure become zero, only can preceed.
※If the water spouting off the pipe line, it may dirty the surrounding and there is a risk to get hurt.

Caution

- To maintain this product's function & performance, please perform daily checking and regular inspection.
- To dismantle the valve, please perform by the skilled specialist (facility contractor).
※If done by normal people, the valve may lost the adjusting function.

Caution

- Other than main body have strainer, this product's needle valve at inlet side in the pilot tube also have strainer, if foreign matter stick to the strainer, please remove it.
※If the strainer clogging, the valve may not function.

7. Cause & Counter Measure Of Multifunction

Condition	Possible Cause	Countermeasure
Outlet side pressure increase	The valve body have plenty of air	Please releaf the air out of the valve body. Refer to 5. Operation Manual.
	Foreign Particles stuck in the valve (Stick at seat ring, shield ring, Pilot valve's seat ring and shield ring)	Remove the foreign particles.
	Part's Damage (Seat ring, shield ring, Pilot valve's seat ring and shield ring)	Exchange the main body shield ring, and pilot valve shield ring. PRV main body seat ring, pilot valve body seat ring part if serious damage, please exchange the part.
	The valve body's stem can't operate smoothly. (Stem, seat, guidebush)	Use cloth file to filing the stem, make it smooth to operate.
	Pilot valve's diaphragm damaged.	Exchange the part
	Strainer clogging	Clean the strainer mesh
Outlet side pressure does not rise	The valve body's stem can't operate smoothly. (Stem, seat, guide bush)	Use cloth file to filing the stem, make it smooth to operate.
	Wrong selection of the sizes (Nominal diameter too small)	Reconfirm the specification and change the nominal diameter sizes.
	Piping resistance too big	Checking the piping
Operation Failure (Pulsation, vibration, pressure unstable)	Air pocket in the piping	Proceed to releaf the air, or install the air vent
	Wrong selection of the sizes	Reconfirm the specification and change the nominal diameter sizes.
	Pressure reduction ratio too big	Do two steps pressure reducing
	Poor adjustment of the needle valve	Small opening of the needle valve, the disc assembly of the PRV body easy to operate and also insensitivity easily. If opening too big, the disc assembly of the valve body, operation easily become unstable and acutely.

8. Nominal Size Selection Chart(For water)

Flow measurement

PRESSURE REDUCING VALVE Nominal Size Selection Chart(For water)-60°C

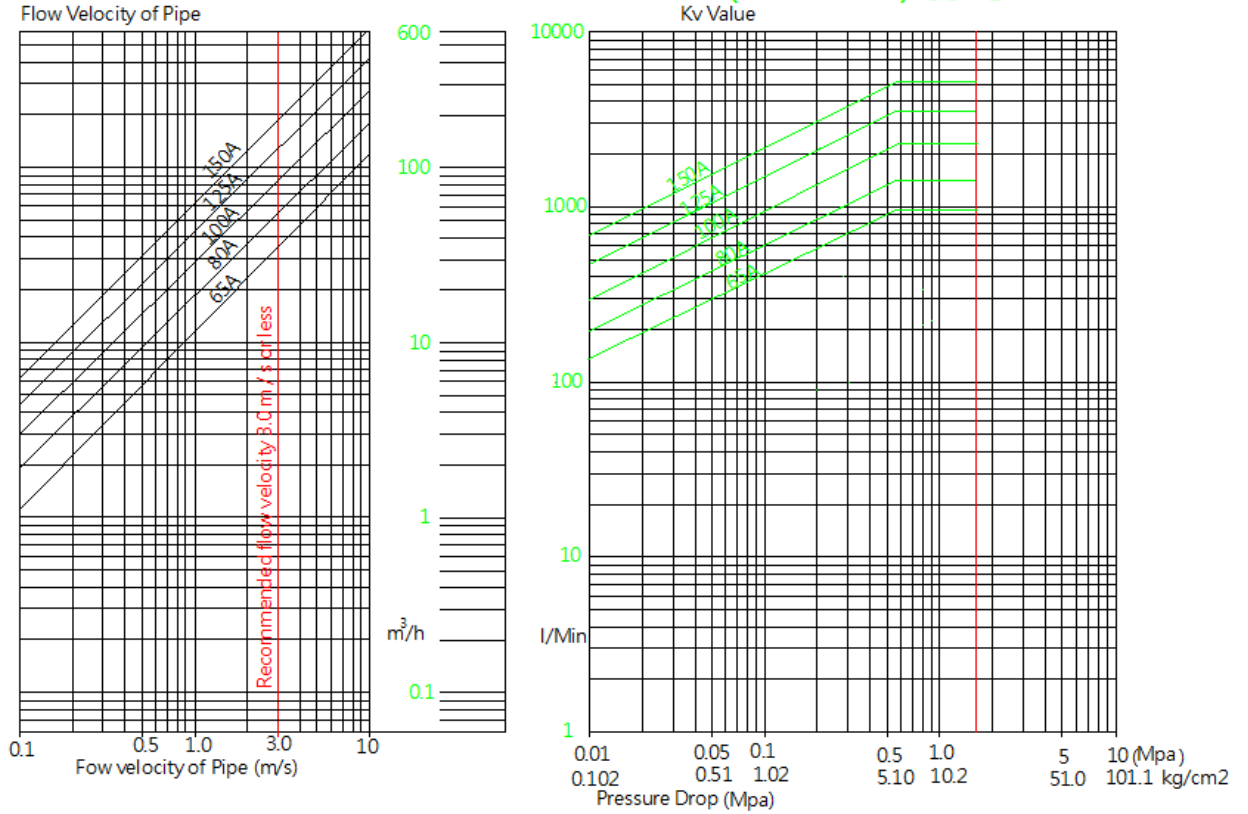

Size	65A	80A	100A	125A	150A
Kv	23.9	36.2	56.5	88.3	127.2
Kvc	56.5	85.6	133.7	208.9	301.0

Kv: Flow rate is equate to a velocity of 2 m/s from EN 1267.

Kvc: Corrected Flow rate by critical differential pressure. Chok pressure

TOZEN