

| Tolerance on overall length(OAL). | | | | |
|-----------------------------------|--------------|------------|--------------|---------------|
| OAL | Nominal size | up to 100A | 125A to 400A | 450A to 1000A |
| up to 500 | | ±3 | ±4 | ±6 |
| 501 to 1000 | | ±4 | ±5 | ±8 |

| Rev.No. | Revision note. | Date | Revised by |
|---------|----------------|------|------------|
| | | | |

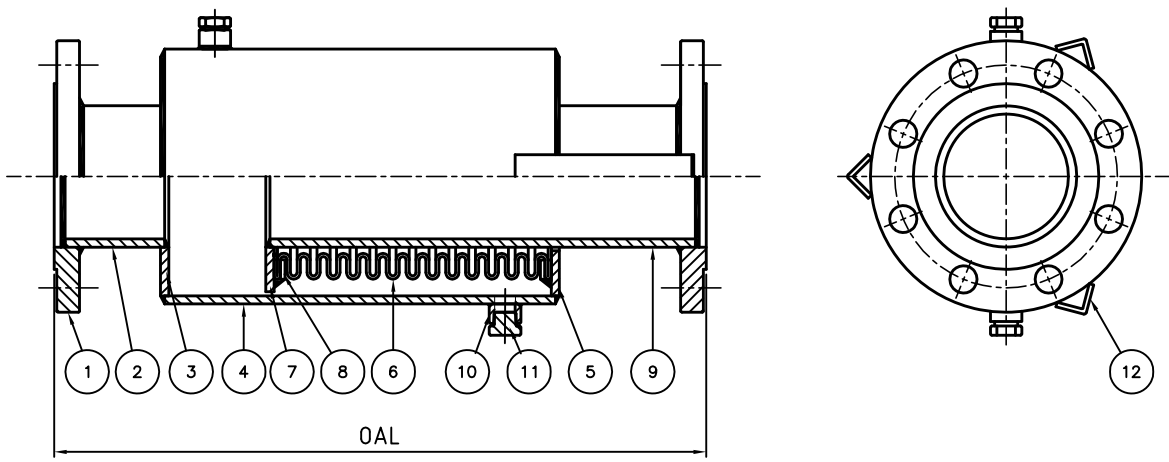

| Item No. | SIZE mm(inch) | OAL (mm) | Working Pressure (Bar) | Working Temperature (Deg.C) | Axial movment (mm) | Q'ty |
|----------|---------------|----------|------------------------|-----------------------------|--------------------|------|
| 1 | 25A(1") | 475 | 10 | 200 | -50 | |
| 2 | 32A(1-1/4") | 475 | 10 | 200 | -50 | |
| 3 | 40A(1-1/2") | 475 | 10 | 200 | -50 | |
| 4 | 50A(2") | 500 | 10 | 200 | -50 | |
| 5 | 65A(2-1/2") | 550 | 10 | 200 | -50 | |
| 6 | 80A(3") | 750 | 10 | 200 | -75 | |
| 7 | 100A(4") | 800 | 10 | 200 | -100 | |
| 8 | 125A(5") | 800 | 10 | 200 | -100 | |
| 9 | 150A(6") | 580 | 10 | 200 | -100 | |

Note : - Holes on flange may not shown the number in fact.
 - Any information provided in drawing is subject to change without notice for error rectification or design modification.

| | | CUSTOMER NAME | | |
|------|------------------------|---------------|------|----------------------------|
| | | PROJECT NAME | | |
| 12 | Shipping bar | SS400 | 2or3 | Removed after installation |
| 11 | Drain plug | SS400 | 2 | 3/4"-BSPT |
| 10 | Female pipe | SS400 | 2 | |
| 9 | Inner pipe | SS400 | 1 | |
| 8 | Half ring | SUS304 | 2set | |
| 7 | Guide ring | SS400 | 1 | |
| 6 | Stainless Steel Bellow | SUS304 | 1 | |
| 5 | Cap ring | SS400 | 1 | |
| 4 | Outer pipe | SS400 | 1 | |
| 3 | Band ring | SS400 | 1 | |
| 2 | Short pipe | SS400 | 1 | |
| 1 | Fix flange | SS400 | 2 | |
| Item | Part Name | Material | Q'ty | Remarks |

| | | | | | |
|--|--|---|--------------|---|----------------------------|
| | | Wellgrow Industrial Estate 126 Moo 9 Bang Wao, Bangpagong, Chachoengsao 24180 Phone: 038-522-255 Fax: 038-522-254 | | PROPRIETARY DATA THIS DOCUMENT CONTAINS TOZEN INDUSTRIAL CO., LTD. CONFIDENTIAL AND PROPRIETARY INFORMATION AND CANNOT BE USED, DUPLICATED OR DISCLOSED IN WHOLE OR IN PART EXCEPT WITH EXPRESS WRITTEN PERMISSION OF TOZEN INDUSTRIAL CO., LTD. | |
| | | DRAWN CHK'D APPV'D | NAME DATE | TITLE EXPANSION JOINT, SJT-4100 DWG NO. PREXX-XXX MATERIAL - | SCALE N/A UNIT mm |

78E0-10750S