

| | | |
|---------------------------------------|------------------------------------|----|
| Finishing other than special comment. | Unit | mm |
| Corner other than special comment. | Radius other than special comment. | |
| Tolerance other than special comment. | | |

| | | | |
|---------|----------------|------|------------|
| Rev.No. | Revision note. | Date | Revised by |
|---------|----------------|------|------------|

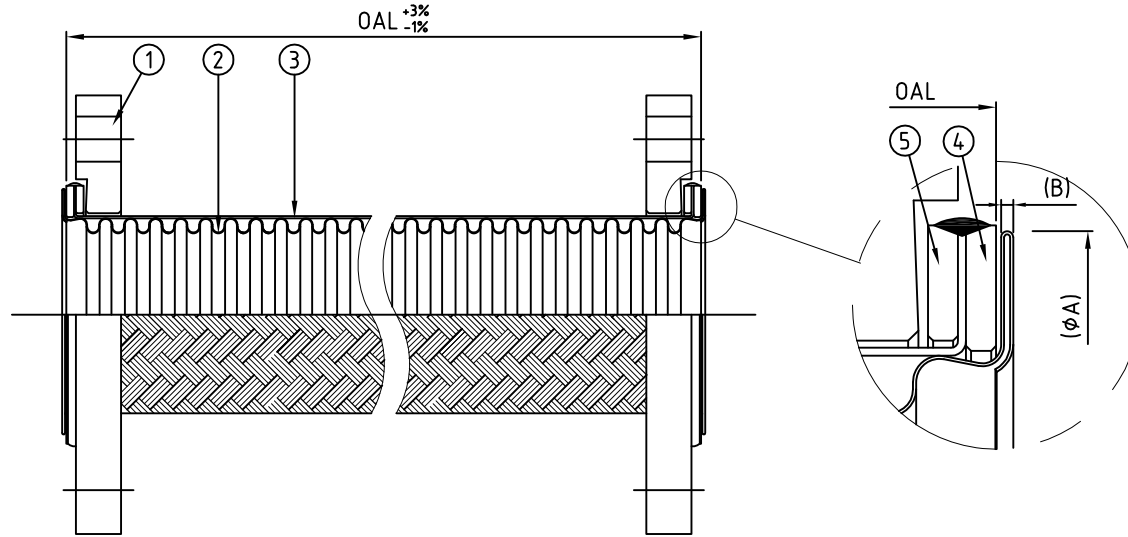

| SIZE | φA (mm) | B (mm) | Min.Bending Radius (mm) | Lateral Movement (mm) | | | Ineffective Length (mm) |
|-------------|---------|--------|-------------------------|-----------------------|----------|----------|-------------------------|
| | | | | OAL300mm | OAL500mm | OAL800mm | |
| 65A(2-1/2") | 98 | 1.2 | 410 | 36 | 118 | 312 | 54 |
| 80A(3") | 118 | 1.6 | 450 | 32 | 106 | 289 | 58 |
| 100A(4") | 140 | 1.6 | 560 | 26 | 86 | 237 | 58 |
| 125A(5") | 178 | 2.4 | 660 | 22 | 73 | 203 | 58 |
| 150A(6") | 214 | 3.2 | 815 | 17 | 58 | 165 | 61 |
| 200A(8") | 263 | 3.2 | 1015 | 13 | 46 | 131 | 67 |
| 250A(10") | 310 | 3.2 | 1220 | 10 | 37 | 108 | 71 |
| 300A(12") | 370 | 4 | 1420 | 8 | 31 | 92 | 74 |

| 5 | BACK RING | SS400(Nickel-Plated) | 2 | IH-14-001/03-00 |
|------|--------------------|----------------------|------|-----------------|
| 4 | FRONT RING | SS400(Nickel-Plated) | 2 | IH-14-001/02-00 |
| 3 | WIRE BRAID | SUS304 | 1 | - |
| 2 | FLEXIBLE HOSE | SUS304 | 1 | - |
| 1 | NON WELDING FLANGE | SS400(Zinc-Plated) | 2 | IH-14-001/01-00 |
| Item | Part Name | Material | Q'ty | Remarks |



Wellgrow Industrial Estate
126 Moo 9 Bang Wao, Bangpagong,
Chachoengsao 24180

Phone: 038-522-255
Fax: 038-522-254

PROPRIETARY DATA

THIS DOCUMENT CONTAINS TOZEN INDUSTRIAL CO., LTD.
CONFIDENTIAL AND PROPRIETARY INFORMATION AND CANNOT
BE USED, DUPLICATED OR DISCLOSED IN WHOLE OR IN PART
EXCEPT WITH EXPRESS WRITTEN PERMISSION OF
TOZEN INDUSTRIAL CO., LTD.

| | | | | | | |
|--------|------|------|----------|-----------|--------|-----------------------|
| DRAWN | NAME | DATE | TITLE | SF6700-NW | Method | |
| CHK'D | | | DWG NO. | PREXX-XXX | Size | A4 |
| APPV'D | | | MATERIAL | - | SCALE | - UNIT mm REVISION 00 |